

DATASHEET AND INSTALLATION INFORMATION

1. Machine configuration and overall dimensions



Technical data	
Brew chamber	1 x up to 24 g (0.05 lb)
Grinder	2 x ceramic burrs 64 mm
User Interface	1 x Touch screen 10.1"
Bean hopper	2 x 1.5 kg (3.3 lb)
Coffee outlet height	190 mm (7.48 in) max.
Hot water outlet height	150 mm (5.9 in) max.
Interface	USB, Ethernet, Serial, RS-232, 2 x CCI
Cup heater surface	Up to 64 espresso cups
Coffee boiler size	1.5 L (0.39 gal)
Steam boiler size	5 L (1.32 gal)
Grounds drawer	700 g (1.54 lb)
Water Connection	
Water hose	Inox braided pipe G3/8" female x 2 m (78.7 in)
Drain hose	Ø 22 x Ø 16 x 2 m (Ø 0.9 x Ø 0.6 x 78.7 in)

Enigma Classic	E'2s	E'2m
Weight	83 kg (183 lb)	87 kg (192 lb)
Performance (up to)		
Espresso/hour at 23 s extraction time	175	
e'Foam Micro Air Dosing (MAD) system (controlled electronically)	Yes	Yes
Hot water portions/hour (200ml (6.8 oz US))	150	
Milk system Cappuccino/hour with Electronic Milk Texturing-system» (EMT) at 23 s extraction time	-	175
Voltage/Power		
1/N/PE, 220-240 V~, 50/60 Hz, 16A	2800 W	
2 x 1/N/PE, 220-240 V~, 50/60 Hz, 16A - EU/IL	5100 W	
1/N/PE, 220-240 V~, 50/60 Hz, 25A - EU	5100 W	
2 x 1/N/PE, 220-240 V~, 50/60 Hz, 25A - EU/IL	7400 W	
3/N/PE, 380-415 V~, 50/60 Hz, 16 A - EU/IL	7400 W	
3/PE, Δ 220-230 V~, 50/60 Hz, 20A - EU	5100 W	
2/PE, 208 V~, 60 Hz, 15A - US/CA	2300 W	
2/PE, 208 V~, 60 Hz, 30A - US/CA	4200 W	
2 x 2/PE, 208 V~, 60 Hz, 30A - US/CA	6100 W	
200 V~, 50/60 Hz, 12A - JP	2100 W	
200 V~, 50/60 Hz, 30A - JP	5600 W	
1/N/PE, 220 V~, 60 Hz, 16A - KR	2600 W	
1/N/PE, 220 V~, 60 Hz, 25A - KR	4700 W	
3/N/PE, 380 V~, 60 Hz, 16A - KR	6800 W	
Frequency	50/60 Hz	
Power consumption (machine on)	Up to 7400 W	
Power consumption (standby mode)	Less than 2 W	
Water pressure and flow		
2.5 - 4 bars (36.3 - 58 psi) If the pressure exceeds 4.5 bars, it is necessary to install a pressure valve reducer.		
If the main flow rate is under 200 L/h, there is a risk of damaging the water pump.		

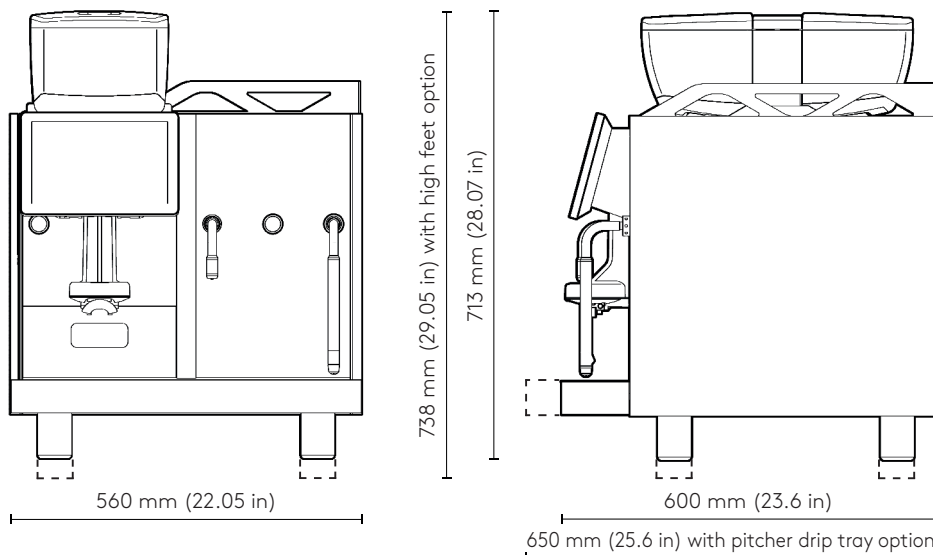

2. Prior to the installation READ SAFETY INSTRUCTIONS

- Check water quality and pressure
- Define filter type and size and check space inside counter
- If no descaling cartridge is used, install carbon filter as minimum
- Check that the machine is on flat and stable surface
- Check counter cut out
- Check water supply installation
- Check that power supply conforms to local standards
- Check that power supply conforms to the machine settings
- Check that the machine is the only device on this power line
- Check all with customer on site
- Make sure original coffee is available
- Make sure cold milk is available (option)
- Check drink recipes and cup sizes
- Check that a milk pitcher is available.

3. After installation

- Explain cleaning and instruct staff using Quick Reference Card
- Fill in and sign the installation form and send it back to Eversys -> orders@eversys.com

4. Desk preparation and countertop cut out dimensions

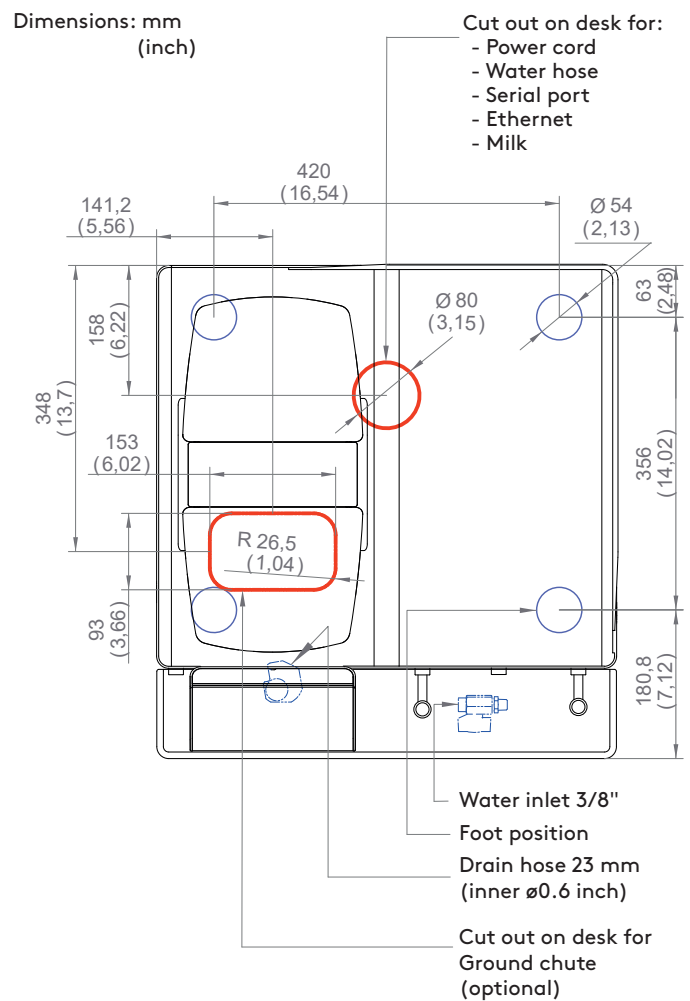
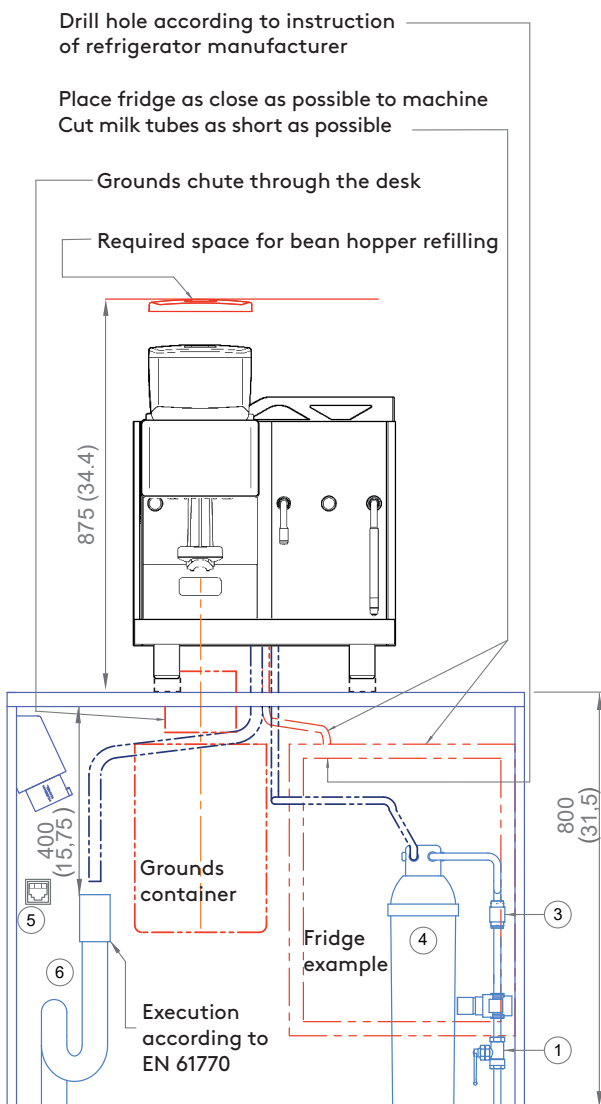

1. Main water inlet
2. Pressure reducer output 3 bar (43,5 psi)
3. Check valve
4. Descaling cartridge or carbon filter as minimum
5. Electrical socket according to local regulation and RJ-45 connection (e'Connect)
6. Drain with syphon, top end min. 56 mm diameter (2.2 inch)

Water quality recommendation

Total hardness: 5 - 8° dGH (89-142 ppm)
 Carbonate hardness: Max. 6° dKH (107 ppm)
 pH value: ideal 7.0 - 7.2